

Microcontroller section

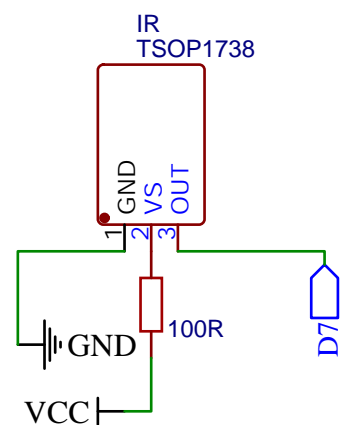

Receiver Section

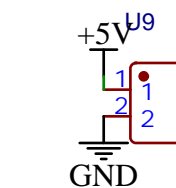
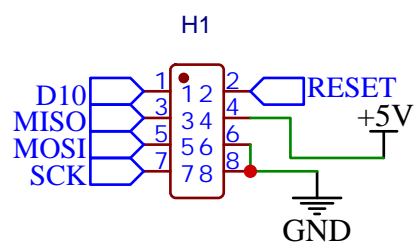
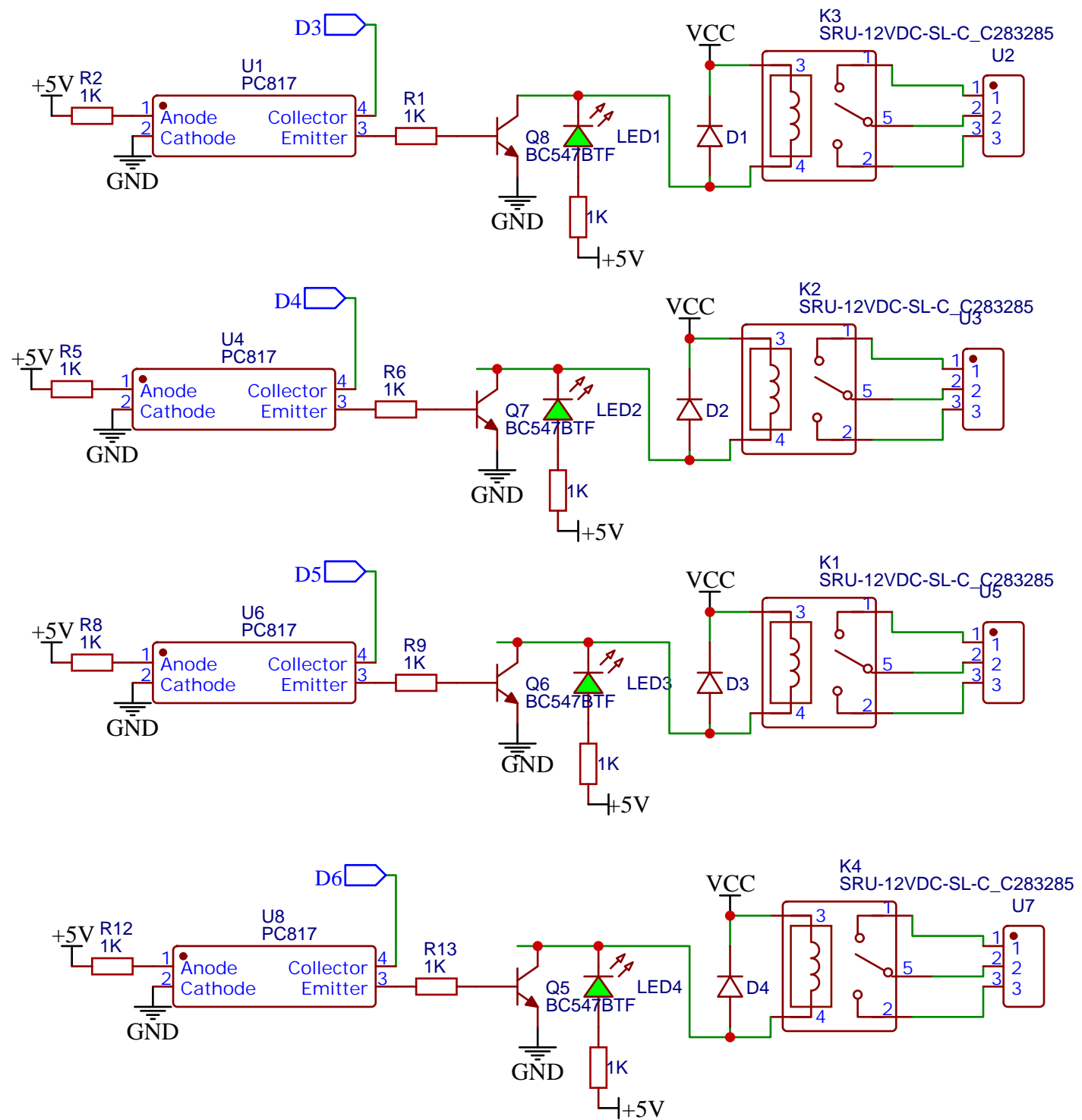

Switching and Relay unit

TITLE: Sheet_1		REV: 1.0
EasyEDA	Company: Your Company	Sheet: 1/1
	Date: 2021-09-25	Drawn By: sagar saini